



PGM
MGT

CYCL
CALL



CYCL
DEF

APPR
DEP

CC \oplus

I

LBL
SET

LBL
CALL

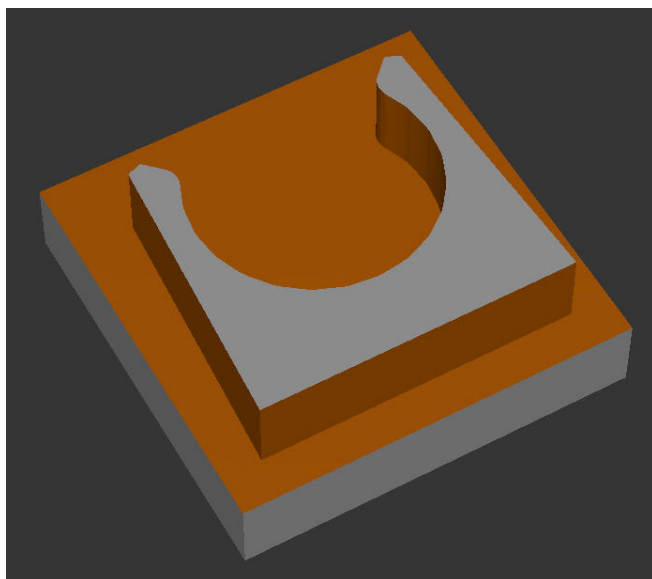
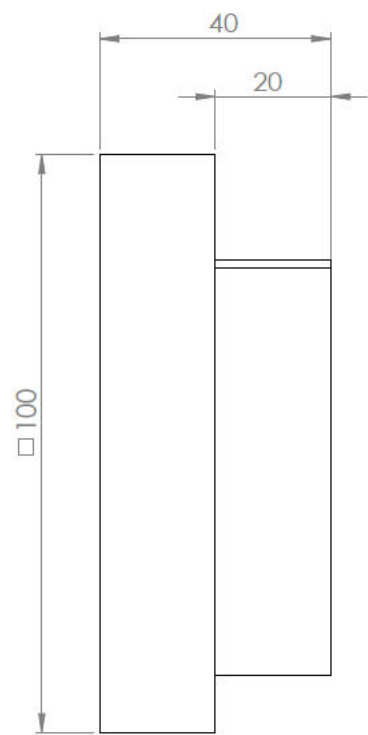
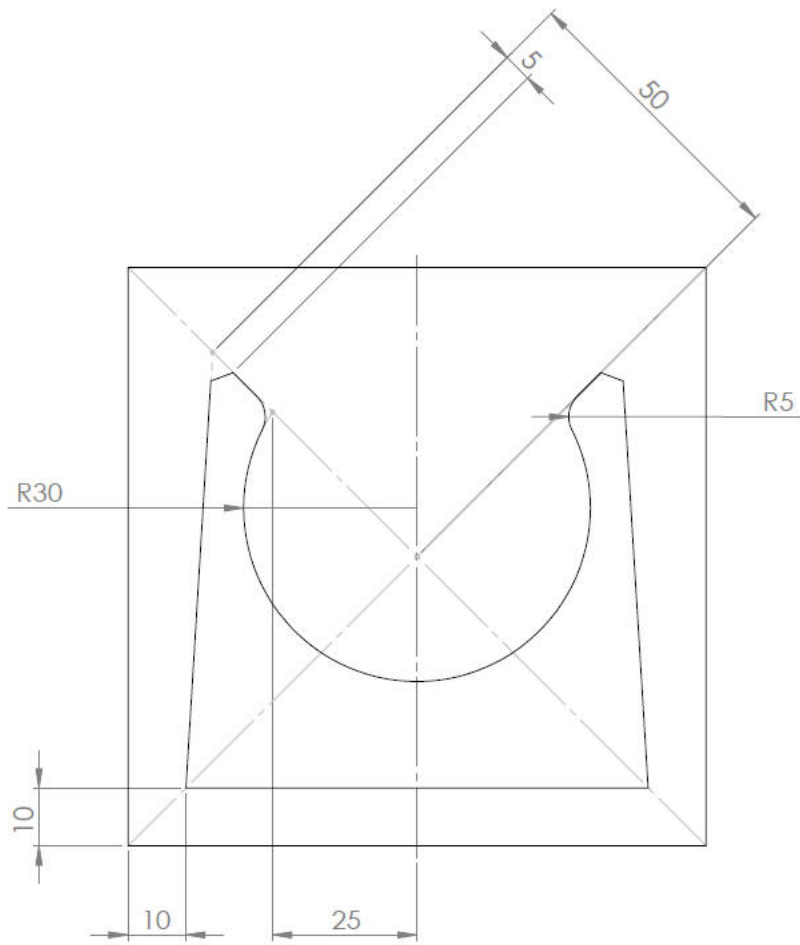

```

0 BEGIN PGM KURSNIVEAU MM
1 BLK FORM 0.1 Z X+0 Y+0 Z-40
2 BLK FORM 0.2 X+100 Y+100 Z+0
3 ;
4 * - Aussenkontur
5 ;
6 TOOL CALL "MILL_D40_ROUGH" Z S5000
7 L Z+100 R0 FMAX M3
8 CYCL DEF 14.0 KONTUR
9 CYCL DEF 14.1 KONTURLABEL1
10 CYCL DEF 270 KONTURZUG-DATEN Q390=+2 ;ANF »
11 CYCL DEF 25 KONTUR-ZUG Q1=-20 ;FRAESTIEFE »
12 CYCL CALL
13 M2
14 LBL 1
15 L X+10 Y+10
16 CC X+50 Y+50
17 LP PR+50 PA+135
18 CHF 5
19 L X+25 Y+75
20 RND R5
21 CR IX+50 R-30 DR+
22 RND R5
23 LP PR+50 PA+45
24 CHF 5
25 L X+90 Y+10
26 L X+10
27 LBL 0
28 END PGM KURSNIVEAU MM

```

